

Installation and Operating Instructions

KEMPER KHS-Mini System Control Unit

-MASTER- Figure 686 02 005

-SLAVE- Figure 686 02 006



1. KHS-Mini system control unit -MASTER-
Figure 686 02 005



2. KHS-Mini system control unit -SLAVE-
Figure 686 02 006

Contents

- 1. Application Area..... p. 2
- 2. Safety..... p. 2
- 3. System Overview..... p. 3
 - 3.1 Application -MASTER- and -SLAVE-..... p. 3
 - 3.2 MASTER/SLAVE-Technology..... p. 4
 - 3.3 Parameterisation and Analysis..... p. 5
- 4. Attributes / Technical Data..... p. 5
- 5. Installation..... p. 6
 - 5.1 Wall Installation..... p. 6
- 6. KHS-Mini System Control Unit Connection..... p. 6
 - 6.1 Terminal Description..... p. 8
 - 6.2 Detailed Illustration of Terminal Cable Configurations..... p. 9
 - 6.3 -MASTER- and -SLAVE- CAN-Bus Connection..... p.10
 - 6.4 KHS Flowmeter Valve Connection..... p.11
 - 6.5 Volume rate measurement with KHS vortex flow sensor p.11
 - 6.6 Temperature measurement with Pt1000..... p.12
 - 6.7 KHS Temperature Sensor Pt1000 Connection..... p.12
 - 6.8 KHS Free Discharge with overflow monitoring Connection p.13
 - 6.9 Potential-Free Alarm Relay Connection..... p.13
 - 6.10 Taking MASTER/SLAVE into Operation..... p.14
- 7. Menu Operation / Functions..... p.14
 - 7.1 Overview Window..... p.14
 - 7.2 Main Menu..... p.17
 - 7.3 Setting the Time and Date..... p.18
 - 7.4 Setting Flushing Times and Weekly Flushing Programs..... p.18
- 8. Start-Up..... p.18
 - 8.1 Network Setup/Settings..... p.19
 - 8.2 Hardware Setup..... p.19
 - 8.3 Valve Function Test in Manual Operation..... p.20
 - 8.4 Operation Modes..... p.20
 - 8.5 System Settings..... p.22
 - 8.6 Program Changeover at MASTER..... p.24
 - 8.7 Journal..... p.25
- 9. Description of malfunctions and malfunction repair..... p.26
- 10. Dimensions, Installation Dimensions..... p.28
- 11. Accessories..... p.28
- 12. Wiring Advice for KEMPER KHS Components with Power Connection..... p.29



1. Application Area

The KEMPER KHS-Mini system control unit is suitable for use in small to medium-sized objects such as schools, nurseries, small facilities, industry, department stores, holiday homes, etc. for the compliant operation of drinking water systems. The intelligent MASTER/SLAVE technology enables the initiation of flushing measures for the drinking water system. The corresponding operation modes Time, Temperature and Flushing Volume can be parameterised for each separate flushing group individually. Any performed flushing measure can be created and documented in the form of a flushing journal via the MASTER control unit. Targeted flushing measures help avoid drinking water stagnation and maintain drinking water hygiene in drinking water systems.

2. Safety



The descriptions and instructions contained in these operating instructions apply to the KHS-Mini system control unit. These operating instructions do not take all the possible events and contingencies into account which can occur during the installation, operation and maintenance.

Specifically trained personnel is required to operate the control system (see EN 50 110-1).

Please contact the manufacturer Gebr. Kemper (see below for address) if you can not find all the information and instructions you require in these operating instructions.

The manufacturer of this control unit is unable to accept any liability in case of non-compliance with these operating instructions. These operating instructions contain essential advice which must be complied with in the installation, start-up and maintenance of the product. These operating instructions need to be read by the mechanic as well as the specialist personnel / operator in charge before starting the installation or taking the device into service. To be complied with are not only the general safety instructions listed under this main section on Safety, but also any other special safety instructions contained in other main sections.

2.1 Safety Instructions

Before taking the appliance into operation, please ensure that

- All connections have been established in an appropriate and expert manner, and
- The system is rendered safe according to the state of the art.

All applicable regulations (EN, VDE...) as well as the provisions of local power suppliers need to be complied with.

2.2 Risks in Case of Non-Compliance with Safety Instructions

Any non-compliance with the safety instructions can put people as well as the environment and facility at risk. Non-compliance with the safety instructions results in the loss of all damage claims. In individual cases, non-compliance can for example create the following risks:

- Failure of important appliance functions
- Personal injury by electric or mechanical forces

2.3 Unauthorized Conversion and Replacement Part Production

Appliance conversions or modifications are only permitted in coordination with the manufacturer. Original replacement parts and accessories authorised by the manufacturer serve to maintain appliance safety. The use of any other parts can cancel any liability for the consequences thereof.

2.4 Unauthorized Operation Modes

The operational safety of the delivered appliance is only guaranteed if it is used in a compliant manner. The limit values stated in the documentation may not be exceeded under any circumstances.

3. System Overview

Basic Unit*		KEMPER KHS-Mini System Control Unit MASTER/SLAVE					
Function Overview		Flushing group** with components Freely selectable combination of individual components					
		Basic Unit	Individual Components				
Operation mode	Time-controlled flushing	X	X	X	X	X	X
	Specified flushing volume				X	X	X
	Temperature-controlled flushing			X	X	X	X
	Combined operation modes			X	X	X	X
Overflow monitoring with alarm and alarm lock			X				X
Number of flushing groups with program assignment		1-MASTER- + 31-SLAVES- max.					
Parameterisation and flushing journal		USB cable + software, connecting -MASTER- to client PC (minimum system requirement: Windows XP or higher)					

Illustration 1: KEMPER KHS-Mini system control unit MASTER/SLAVE with functions and operation modes

3.1 -MASTER- and -SLAVE- Application (Example: 1 -MASTER- and 2 -SLAVES-)

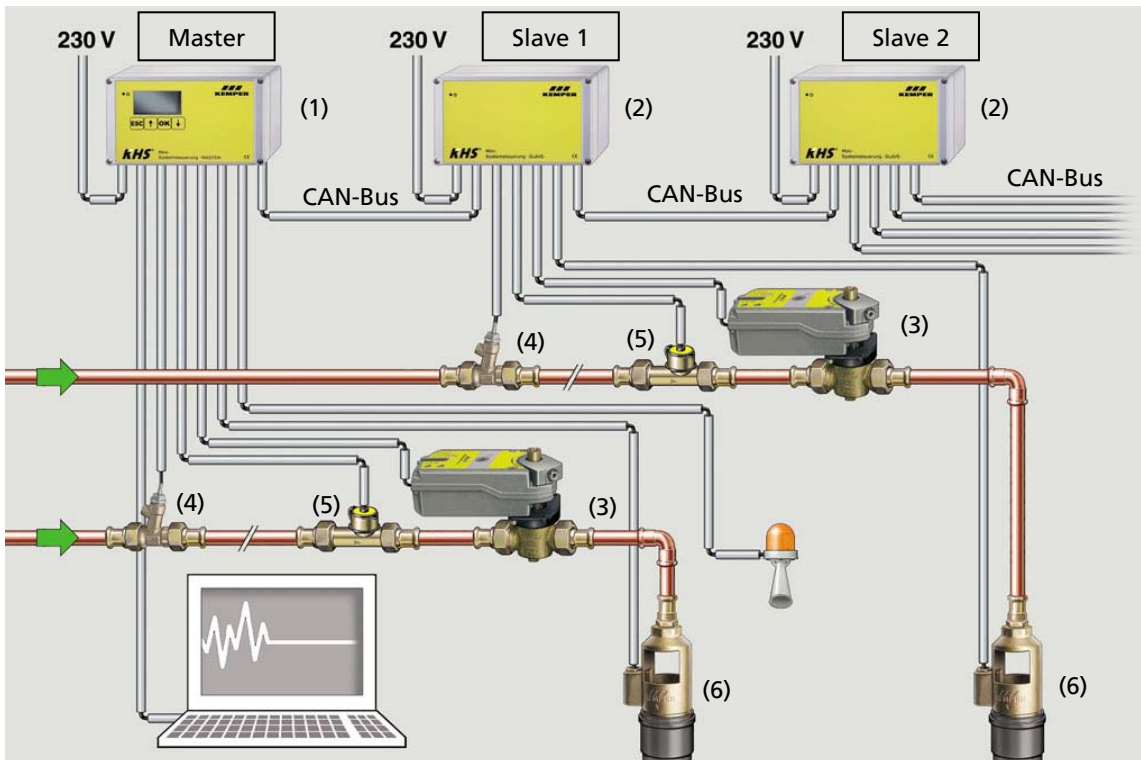

Illustration 2: Example: 1 -MASTER- and 2 -SLAVES- combined with installed actuators/sensors

System example: 1 x -MASTER- (1) and 2 x -SLAVE- (2) with flushing valve (3), temperature sensor (4), volume flow sensor (5), as well as overflow monitoring (6) connected via CAN bus.

3.2 MASTER/SLAVE Technology

The smallest solution within a basic design for performing flushing measures consists of the KHS MASTER control unit with one flushing valve. This -MASTER- control serves to trigger the flushing valve and analyse the signals. But the CAN bus technology integrated in the -MASTER- unit allows for the control of up to 31 additional SLAVE control units directly via this -MASTER- unit. This means that up to 32 KHS flushing groups (flushing valve, temperature sensor and flowmeter sensor) can be connected via the MASTER/SLAVE technology in buildings. The arrangement/sequence of the MASTER / SLAVE control units is meanwhile freely selectable. The -MASTER- unit can be positioned as the first control unit or in between the -SLAVE- control units.

Example 1: Arrangement variants for MASTER/SLAVE control units

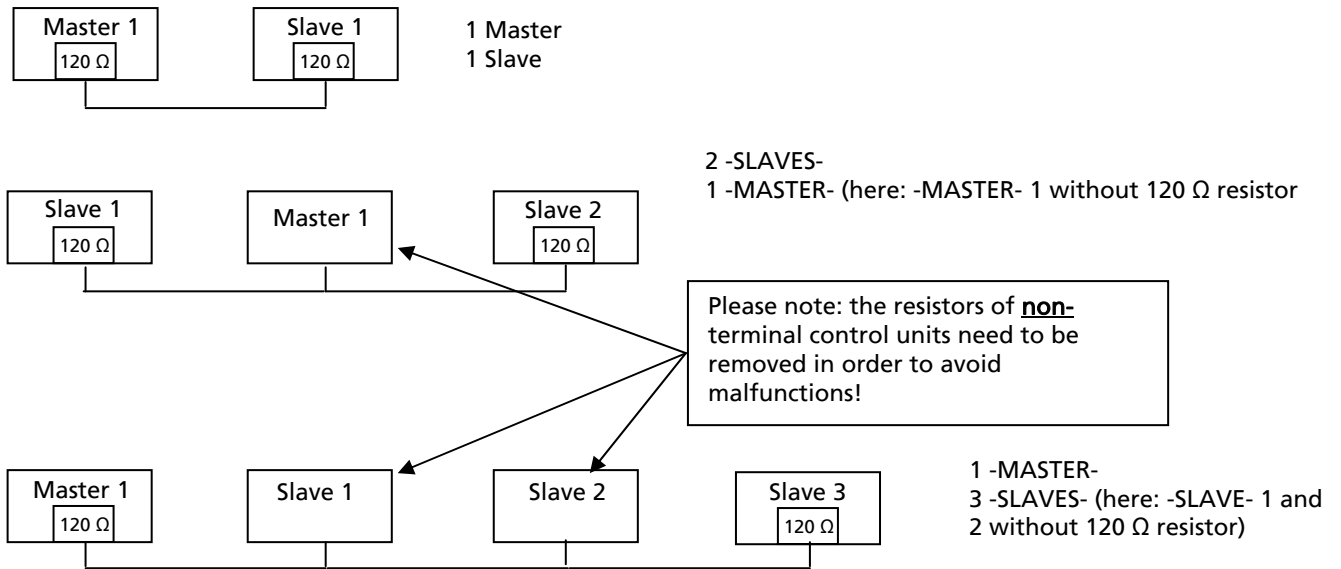

Instructions for 120 Ω end resistor

The MASTER/SLAVE arrangement within the CAN bus chain is freely selectable. The 120 Ω end resistor must only be integrated in the first and last control component.

The steerages must be connected in series. Branchings and star connections are **not** possible!

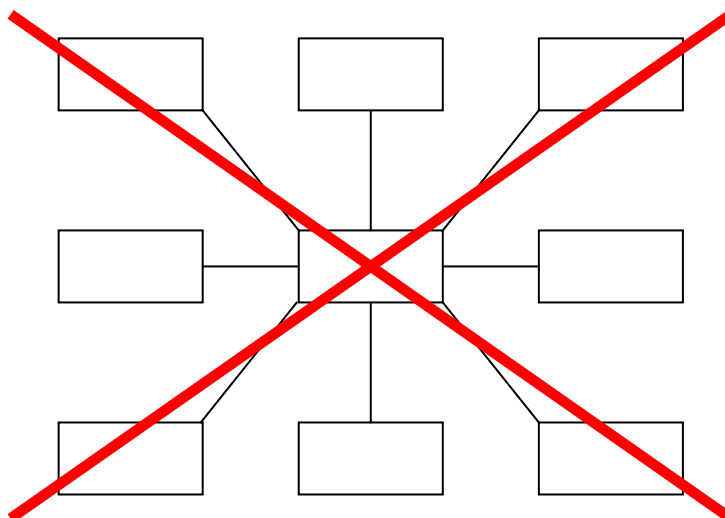
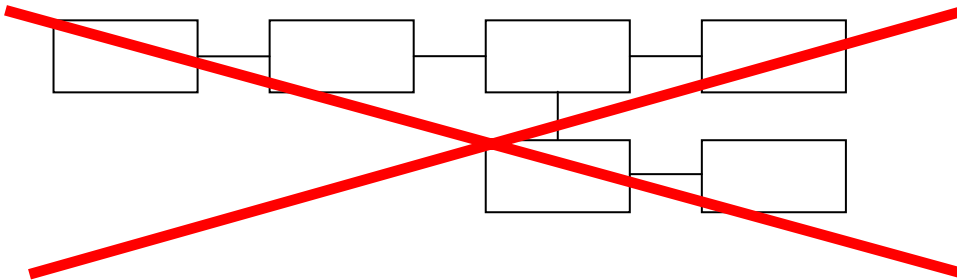

Example 2: 1 MASTER with 3 SLAVE units, CAN bus connection design

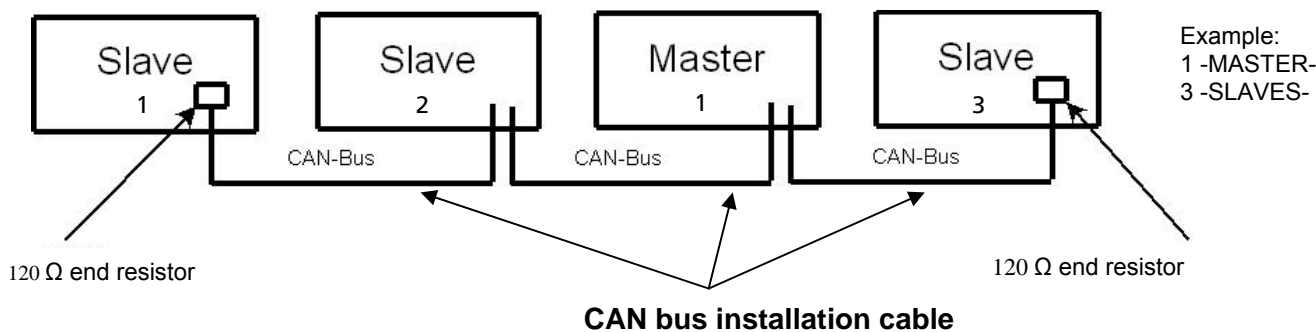

The optional expansion of 1 -MASTER- with up to 31 -SLAVE- units via the CAN bus is established with a sequentially placed (from one control unit to the next) **CAN installation cable**. It is in this respect negligible whether the - MASTER- is positioned within the sequence or at its end. The shortest wiring paths should be used.

The sum total of all the CAN installation cable for the entire bus system may not exceed 1000 m in length.
CAN installation cable, cable lengths, see Table 4

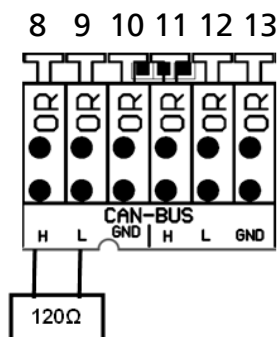

All control units include a 120 Ω end resistor upon delivery (see illustration on left, terminals 8 and 9).

If a control unit is looped through, the resistor needs to be removed, see above in Arrangement Variants for MASTER / SLAVE control units

Please note: the resistors of non-terminal control units need to be removed in order to avoid malfunctions!

3.3 Parameterising and Analysis

The MASTER/SLAVE flushing groups can be parameterised manually at the – MASTER- unit via a 4 button control including Up, Down, Enter, Esc. or, if desired, via an integrated interface at the client’s PC using a parameterising software and USB cable (see optional accessories). 4000 events are continuously being stored, with the PC analysis in this case being performed using a flushing journal in Excel format. All current valve states and sensor data are visualised on the graphic display of the -MASTER- unit. 16 storage locations per control unit for the operation modes or operation mode combinations of time, temperature and flushing volume are freely adjustable.

4. Attributes / Technical Data

- Power supply 230 V AC 50/60Hz
- Back-lit graphic display
- Operation by the 4 keys: up, down, enter, escape
- Relay flushing valve breaking capacity 230 V, 2 A
- Potential-free alarm relay, max. 230 V, 2 A
- 16 storage locations for operation modes:
 - Time
 - Temperature
 - flushing volume
- For connecting:
 - 1 KHS VAV-plus or KHS-VAV
 - 1 KHS Pt 1000 temperature sensor
 - 1 KHS flowmeter
 - 1 KHS overflow monitoring unit
- Acoustic alarm for overflow monitoring (can be deactivated),
- Alarm acknowledgement at the appliance
- Expandable system: 1 -Master- with maximally 31 -SLAVE- units via CAN bus
- Bus system connection: CAN installation cable , max.1000 m total length
- Serial interface cable for client PC connection for parameterising and reading out the flushing journal
- Storage of up to 4000 events
- External 230 V input at -MASTER-, change-over: program 1 (e. g. school holiday program), program 2 (e. g. school program), maintenance operation (system blocked)
- Menu navigation in German, English or Dutch

- Own consumption 3 VA
- Manual valve operation at the appliance
- Ambient temperature from 0 °C to + 50 °C
- Protection grade IP 54
- Surface-mounting shell for wall installation

5. Installation

PLEASE NOTE: Electrical appliances may only be installed and assembled by certified installation engineers.

Very strong magnetic fields can interfere with the unit's functions. Interferences can be avoided by complying with the following installation rules:

- Do not install the control unit or sensors near inductive loads (engines, transformers, contactors, etc.)
- Provide power supply via a separate mains circuit (if required with line filter).
- Inductive loads need to be equipped with protective devices for overvoltage reduction (varistors, RC filters).

If the control unit is used in combination with other appliances within a facility, there is a need to check if this leads to an emission of unwanted signals.

5.1 Wall Installation

The KHS-Mini system control unit is designed for wall installation. The housing features 4 x ø 4 mm fastening holes at a distance of w = 188 mm and h = 88 mm (see section 9. Dimensions). To install the unit, open the lid and attach the appliance to the wall with screws. Establish the required electrical connections after installing the housing.





6. KHS-Mini system control unit connection

The Table 1 „Overview for System Start-Up“ (page 7) needs to be filled in first, in order to correctly connect the control units in combination with the actuators and sensors, and in order to ensure correct terminal configurations.

The information on the serial number and actuators/sensors is essential for being able to take the system into service. It is important in this respect that the MASTER as well as individual SLAVE units are assigned to a location (installation location) and that the sensors/actuators are also assigned to the attendant MASTER / SLAVE units.

Table 1: Overview for System Start-Up at KHS-Mini System Control Unit -MASTER- Fig.686 02 005

(Fill in by hand as shown in example as part of the installation process!)

Entry at "Network Setup" -MASTER- Menu Option			Entry at "Hardware Setup" -MASTER- Menu Option							
Object name:			KHS-VAV Maximum flow ball valve with spring reset servo drive		KHS-VAV Maximum flow ball valve with servo drive		Flow Sensor Fig.138 4G and Fig.638 4G		KHS Temperature Sensor Pt1000	KHS Free Discharge with overflow monitoring
Date:			Figure 686 05/ Figure 696 05	Figure 686 04/ Figure 696 04	Measurement range =>b<= 1.8 - 32 l/min.	Measurement range =>c<= 3.5 - 50 l/min.	Measurement range =>d<= 5.0 - 85 l/min.	Measurement range =>e<= 9.0 - 150 l/min.	Figure 628 0G	Figure 688 00
Person performing start-up:										
Control Unit	No.	Serial No. (type plate on side of control unit)	Place/Room	Example						
MASTER	1	001007	Bldg. 2 / Room 2.03	X	X				X	X
SLAVE	1									
SLAVE	2									
SLAVE	3									
SLAVE	4									
SLAVE	5									
SLAVE	6									
SLAVE	7									
SLAVE	8									
SLAVE	9									
SLAVE	10									
SLAVE	11									
SLAVE	12									
SLAVE	13									
SLAVE	14									
SLAVE	15									
SLAVE	16									
SLAVE	17									
SLAVE	18									
SLAVE	19									
SLAVE	20									
SLAVE	21									
SLAVE	22									
SLAVE	23									
SLAVE	24									
SLAVE	25									
SLAVE	26									
SLAVE	27									
SLAVE	28									
SLAVE	29									
SLAVE	30									
SLAVE	31									

6.1 Terminal Description:

Illustration: control board with terminals

1. Flushing valve – switch out 230 V _____
 2. Flushing valve – current out 230 V (only 68604) _____
 3. Flushing valve – neutral _____
 4. Supply – current in 230V _____
 5. Supply – neutral _____
 6. External input 230 V (function only -MASTER- _____
 7. Protective conductor _____
 8. CAN-Bus HIGH 1 _____
 9. CAN-Bus LOW 1 _____
 10. CAN-Bus GND 1 _____
 11. CAN-Bus HIGH 2 _____
 12. CAN-Bus LOW 2 _____
 13. CAN-Bus GND 2 _____
 14. Flowmeter – current out 5 V _____
 15. Flowmeter – throughflow in _____
 16. Flowmeter – no function _____
 17. Flowmeter – GND _____
 18. Pt1000 – input 1 _____
 19. Pt1000 – input 2 _____
 20. Pt1000 – input 3 _____
 21. Pt1000 – input 4 _____
 22. Free discharge 1 _____
 23. Free discharge 2 _____
- PC interface (only MASTER: _____
Phone jack, no clamp)
24. Alarm relay – external current in _____
 25. Ext. current monitoring = error _____
 26. Ext. current monitoring = operation _____

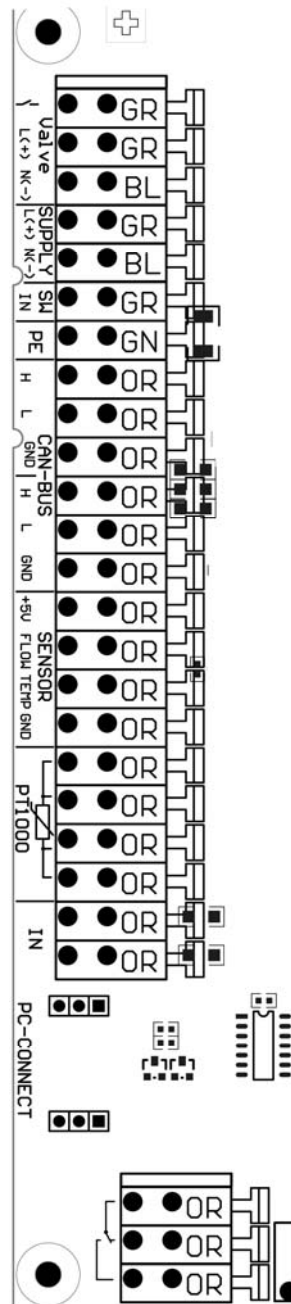

Illustration 3: Section of the control board with terminals

The connection is established via screwless terminals, with the exception of the PC, which is linked to the – MASTER – unit via a jack plug.

The terminals can be opened with a 3 mm wide standard screwdriver by pressing down on the clamping lever. The cable cord is subsequently inserted in the terminal and connected by releasing the clamping lever.

6.2 Detailed Illustration of Terminal Cable Configurations

6.2.1 Power Supply Connection, Terminal Pos. 4, 5, 7:

Power supply: 230 V +/- 15% AC 50/60 Hz

Connection: screwless terminals 4, 5, 7

Series fuse: max. 16 A

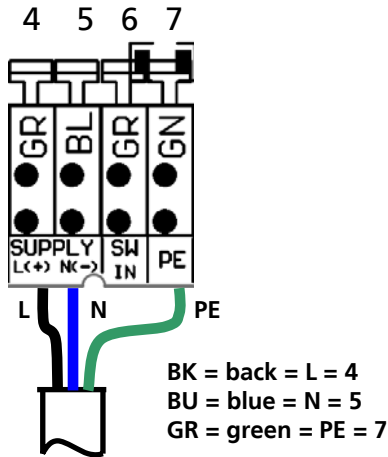
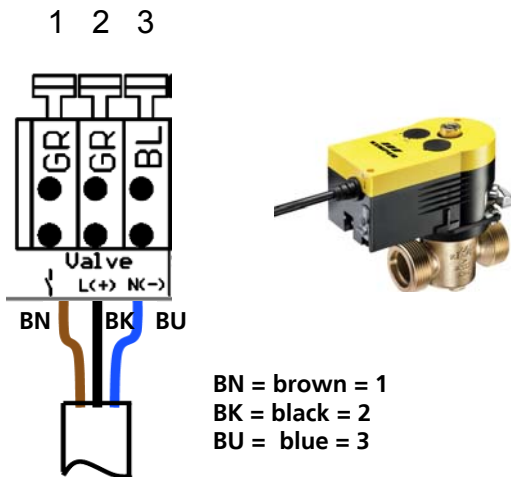

Illustration 4: Configuration terminals 4, 5, 7

6.2.2 Connection VAV with Servo Drive Figure 686 04, Terminal Pos. 1, 2, 3

Flushing valve connection



PLEASE NOTE:

Only 1 valve Figure 686 04 or Figure 686 05 may be connected PER CONTROL UNIT:
not suitable for more than one flushing valve!

Illustration 5: Configuration terminals 1, 2, 3

6.2.3 Connection VAV with Servo Drive Figure 686 05, Terminal Pos. 1 and 3

Connection safety valve V1

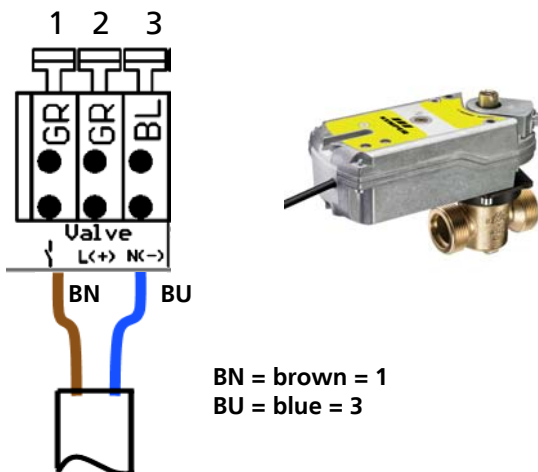

PLEASE NOTE:

Only 1 valve Figure 686 04 or Figure 686 05 may be connected PER CONTROL UNIT:
not suitable for several flushing valves!

PLEASE NOTE:

Terminal 2 remains unoccupied when connecting Figure 686 05!

Illustration 6: Configuration terminals 1, 3

6.2.4 External input 230 V via Switch, Terminal Pos. 6:

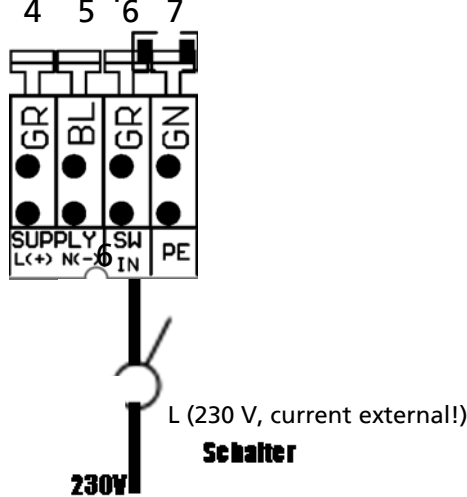

ONLY -MASTER-

Triggering terminal 6 gives you the opportunity to change the KHS-Mini system control unit program using external switching processes via a 230V input.

Illustration 7: Configuration terminals 6

230 V input for program changeover at MASTER

See section 8.6 for program changeover with external 230V input

Switch function: **Program 1**

Menu setting: program change – external input – program 1

Feeds into input 6 230 V, this way program 1 is activated.

Program 1 (e. g. school: normal school operation) overrides program 2 (e. g. school: holidays)

Switch function: **Program 2**

Menu setting: program change – external input – program 2

Feeds into input 6 230 V, this way program 2 is activated.

Program 2 (e. g. school: holidays) overrides program 1 (e. g. school: normal school operation)

Switch function: **locked**

Menu setting: system parameters – external input – system locked

Feeds into input 6 230 V, this way the system is locked and no flushing processes are performed.

The program is suspended, e. g. for maintenance operation

6.3 CAN Bus Connection for -MASTER- and -SLAVE- Control Units, Terminal Pos. 8-13:



1 Twisted-Pair

PLEASE NOTE:

The twisted pair of the CAN bus cable should only be separated to the extent required for terminal configuration (recommended maximum of 1-2 cm).

Illustration 8: Twisted Pair

Example 3: CAN Bus installation for connecting 1-Master- and 3-SLAVE control units: configuration terminals 8-13

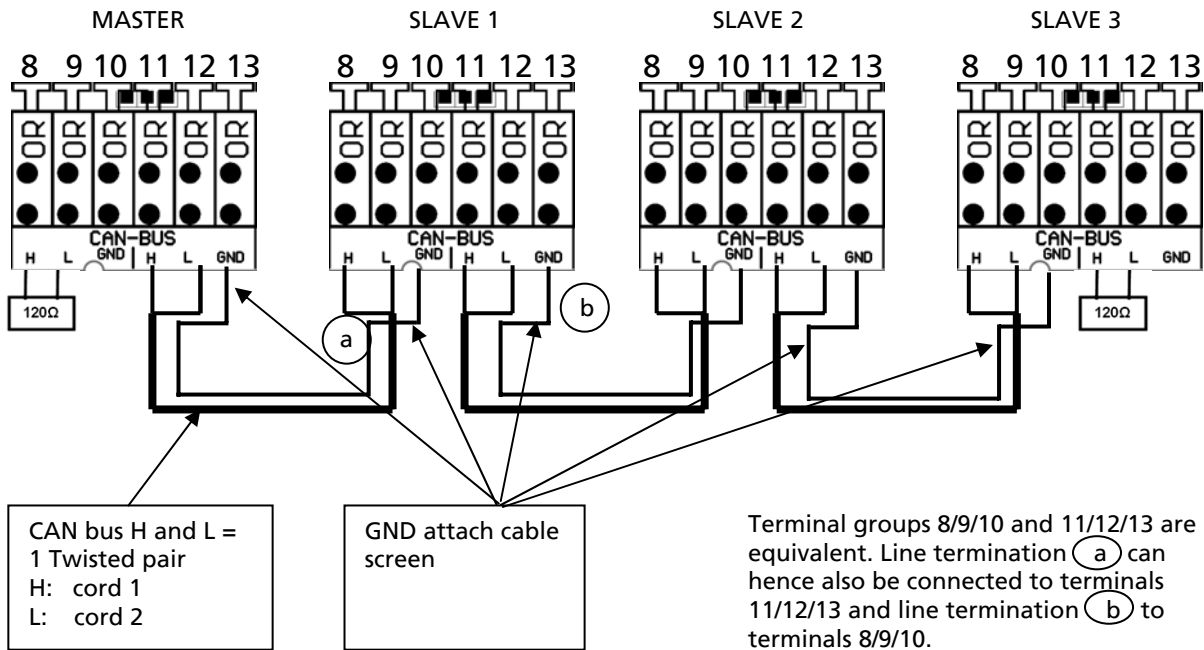

Illustration 9: Configuration terminals 8 - 13 for CAN bus

6.4 Connection KHS Flowmeter Figure 638 00, Terminal Pos.14-17

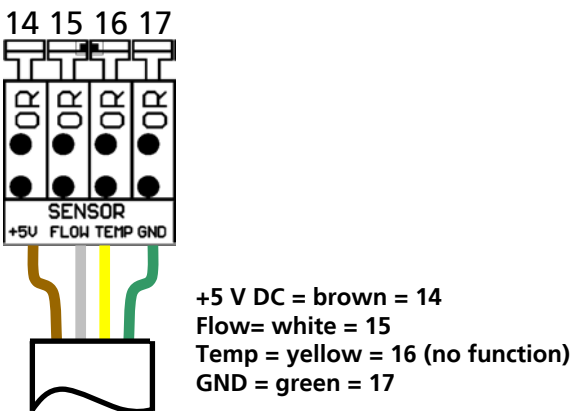
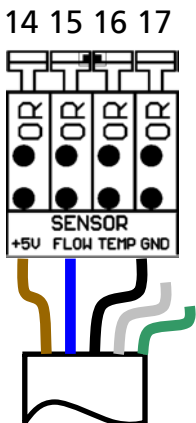

Illustration 10: Configuration terminals 14- 17, volume sensor

6.5 Volume rate measurement with KHS vortex flow sensor Figure 138 4G or Figure 638 4G, connection terminals 14-17

When using the KEMPER Vortex Flow Sensor cable M12x1 with loose strands Figure 138 00 012, to connect the Vortex Flow Sensor Figure 138 4G and Figure 638 4G, use the assignments below:



br = +5 V DC = 14
blue = Flow = 15
Temp = 16 (No function here)
Black = GND = 17

white and green = Pt1000/2
conductor = 19/20
(connection see 6.6)

Caution!
If temperature measurement of the integrated Pt1000 sensor is not required, insulate and protect the strands from contact with the pcb.



6.5.1 Preparing the sensor head-part to complete the cable plug connection

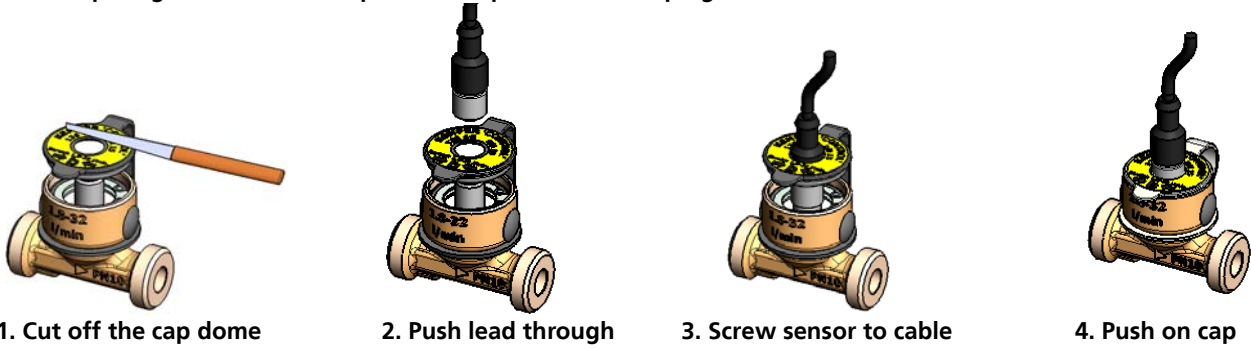

1. Cut off the cap dome
2. Push lead through
3. Screw sensor to cable
4. Push on cap

6.6 Temperature measurement with Pt1000: Connect the Pt1000/2-conductor of the KHS vortex flow sensor Figure 138 4G or Figure 638 4G, connection terminals 19-20

To connect the Vortex Flow Sensor Figure 138 4G and Figure 638 4G, use the assignments below:

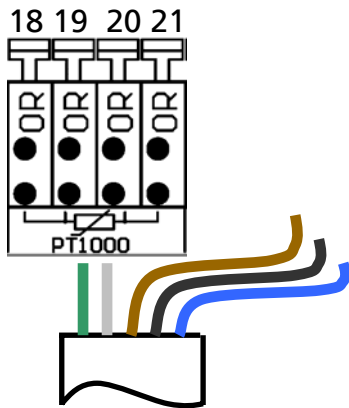

Pt1000 = green = 19
Pt1000 = white = 20

Brown, blue and black strands = flow measurement
Connection see 6.5

Caution!
If the vortex flow sensor is not being used, insulate and protect the strands from contact with the pcb.

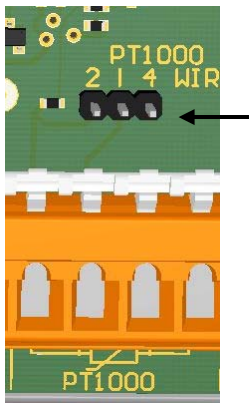

Re-plug the jumper on the pcb from 4-conductor to 2-conductor!

Caution!
During temperature measurements as 2-conductor, the measurements are falsified by the cable resistance.
At 10 m cable length with a 0.34 mm² cable, the measurement falsification could be as high as +0.5°C.

6.7 Connection KHS Temperature Sensor Pt1000 Figure 628 0G / 639 0G, Terminal Pos.18-21

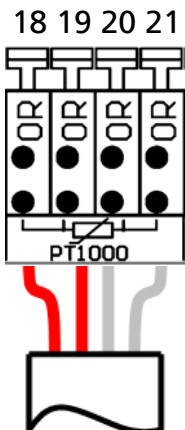

RD= red = 18
RD = red = 19
W = white = 20
W = white = 21



Illustration 11: Configuration terminals 18-21, temperature sensor

6.8 Connection KHS Free Discharge with Overflow Monitoring Figure 688 00, Terminal Pos. 22, 23

22 23

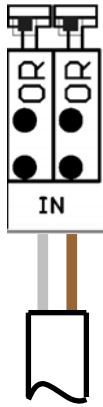

BN = brown = 22
W = white = 23



Upon delivery, a bridging cord is inserted between terminals 22 and 23. This needs to be removed before connecting a free discharge unit.

Illustration 12: Configuration terminals 22, 23 for free discharge with overflow monitoring

6.9 Connection Potential-Free Alarm Relay -MASTER- and -SLAVE- Control Units, Terminal Pos. 25, 26, 27

Indication by indicator light, horn, alarm system, central building control system, etc.
The relay opens in case of alarm! In operation the relay is pulled in!

Monitoring example: errors and mains voltage failures are indicated using external voltage at indicator lamp, alarm horn or central building control system.

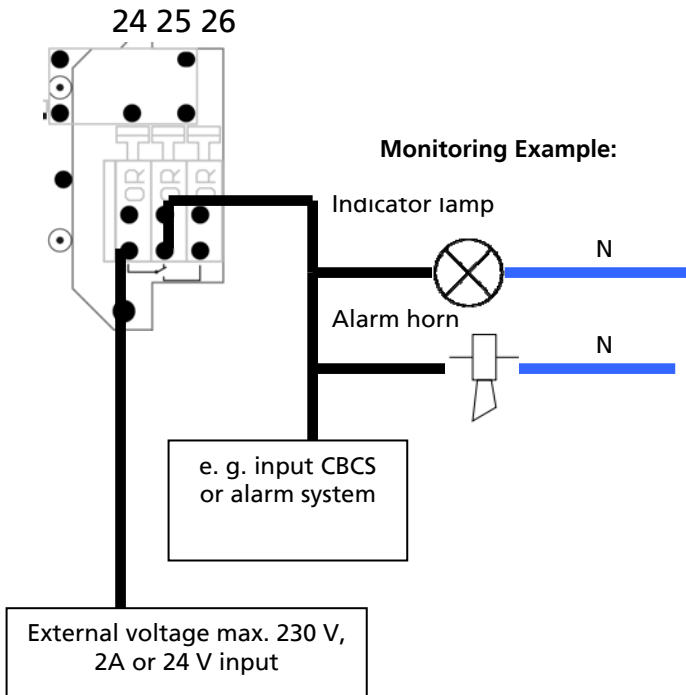

Example 4: Monitoring example with indicator lamp or alarm horn

6.10 Taking the MASTER / SLAVE Control Units into Operation for the First Time

Following the successful assembly / installation and terminal configuration/electrical connection, the 230V line voltage can be applied. PLEASE NOTE: Electrical appliances may only be installed and assembled by certified installation engineers!

Initial settings

1. Switch on 230V mains voltage at MASTER.
2. The KHS logo and software status with date will be displayed for 3 seconds
3. Initial settings: language, time and date

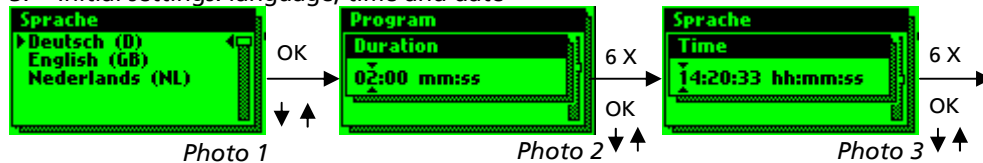

4. View of MASTER following initial settings

P1	1/4	15:22:31
MAS Y	S1.01	S1.01
S1.02	S1.03	S1.03
S1.04	S1.05	S1.05
S1.06	S1.07	S1.07

oto 4

5. **Check!:** *Antenna symbol appears permanently in the overview, LED lights up green permanently.* Possibly connected – SLAVE – units will not be indicated at this point in time. Also the LEDs at the - SLAVE – units are not yet permanently lit green. If yes, continue with start-up in compliance with the instructions. If not, see Table 3 Error Description / Troubleshooting.

The MASTER control unit features the parameterisation for MASTER and SLAVE. The four key functions shown on the right are provided for its operation. Please inform yourself on the functions which can be performed with these first (see section 7).



7. Menu Operation / „Overview“ and „Menu“ Functions (Description commissioning see point 8)

The KHS-Mini system control unit is adjusted and operated via various menus accessible via the MASTER display. Menu access is provided via a control panel at the MASTER unit featuring four control buttons.

Taste 1 ESC: exit the menu/switch between overview and main menu

Taste 2 ↑: scroll back

Taste 3 OK: confirmation button

Taste 4 ↓: scroll forward



The menus have a loop structure, i. e. pressing the ↓-button at the last entry will return you to the first one. The menu will similarly jump from the first to the last entry if the ↑-button is pressed.

Note: If no entry is made for ca. 3 min., the control unit will return to the main display from the settings mode.

The control unit is divided into two areas: **Overview** and **Main Menu**.

7.1. Window (Overview/Main Menu)

Available overview windows: "Overview" and "Main Menu".

The "Overview" window only allows for viewing and surveying states.

The "Main Menu" window allows for viewing and editing pre-set parameters.

This window is PASSWORD-protected.

Illustration 13: Window overviews and functions provided in "General Overview/Main Menu"

Window	
<p>Window "Overview"</p> <p>VIEWING without PASSWORD</p> <p>Functions:</p> <ul style="list-style-type: none"> - Display control status - View network - Hardware setup - Flushing processes - Error states 	<p>Window "Main Menu"</p> <p>VIEWING and EDITING with PASSWORD</p> <p>Functions:</p> <ul style="list-style-type: none"> - Set control parameters - Setup network - Operation mode selection

Example 5: window "Overview": -MASTER- with 1 x SLAVE control unit following start-up (network setup and hardware setup)

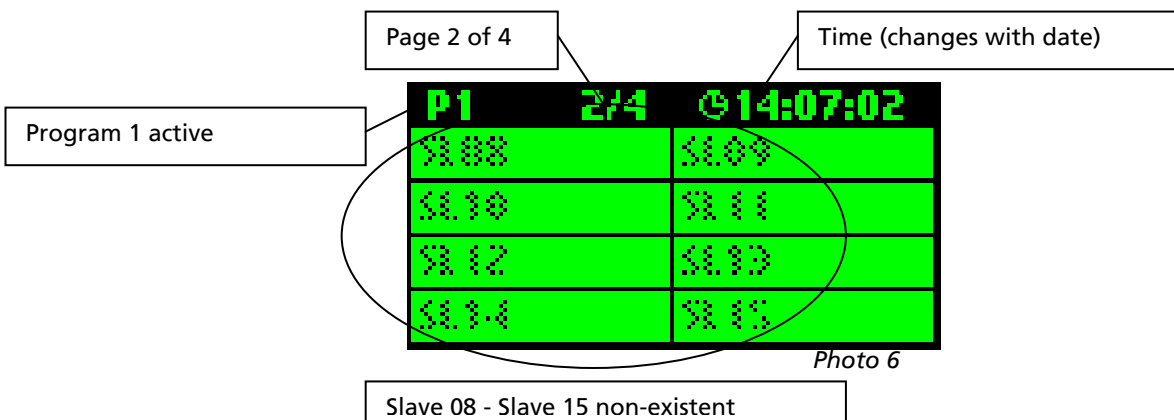
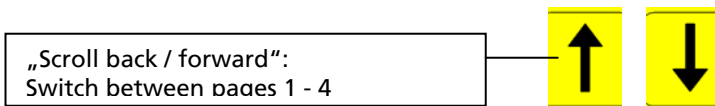
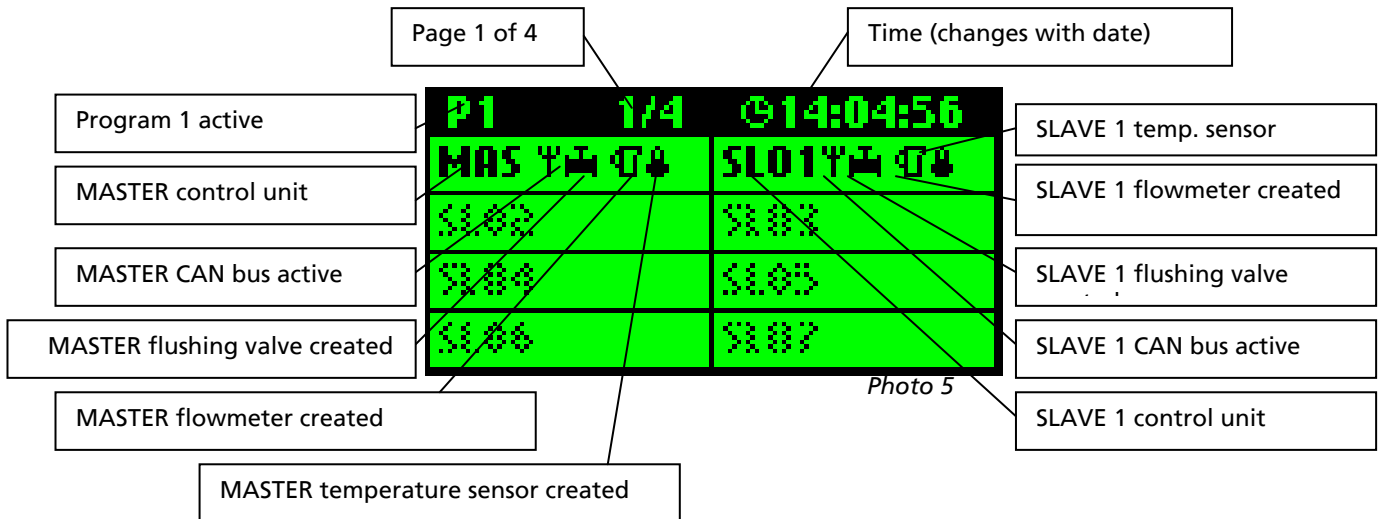

All in all 4 general overview windows featuring 8 control units each are provided for the sum total of 32 control units (1 -MASTER- unit and 31 -SLAVE- units).

Changing from „General Overview“ to „Detailed Overview“

1 x „OK“ select control unit (frame)
2 x „OK“ go to detailed overview





Photo 7

*: A frame appears around the first control unit entry (= top left) on the selected page (1 to 4). Pressing the OK button again will take you to the detailed overview of the selected control unit. Alternatively, another active control unit can be selected via the ↑- or ↓-button. This unit will again be highlighted by a flashing frame. Pressing the OK-button in this case will open the detailed overview of this control unit.

„Detailed Overview“ window example: -MASTER- with 1 x SLAVE control unit following start-up (network setup and hardware setup)

Control unit serial number: SNr: 001007

MASTER CAN bus active: Y

MASTER hardware setup: 04

Flushing duration / time control: 00:00

Date / time: 14:08:14

Control unit name: SLO1

Throughflow valve: 0.0 l/min

Volume / flushing amount: 0.0 Litre

Temperature: 23.3 °C

Photo 8

„Scroll back / forward“:
Switch between detailed view MASTER to SLAVE 31 (if provided)

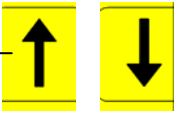

Only active control units can be selected. Deactivated control units will be skipped automatically.

1 x „Esc“ back to Overview



2 x „Esc“ go to main menu



Overview display for flushing processes

„Overview“
Flushing active:
 - Valve symbol goes transparent
 - Time control: clock symbol flashes
 - Volume control: volume symbol flashes
 - Temperature control: temp. symbol flashes
 - Zeitsteuerung: Uhrsymbol blinkt



Photo 9

„Detailed overview“
Flushing active:
 - Valve symbol goes transparent
 - Throughflow is displayed (if flowmeter is provided)
 - Volume is counted (if flowmeter is provided)
 - Flushing duration is displayed
 - Temperature is displayed (if temperature sensor is provided)

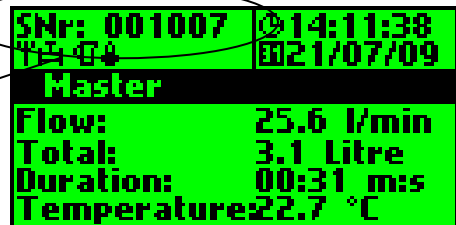

Photo 10

7.2 Main Menu

Functions:

- Control unit setup with password protection: network setup, hardware setup, operation modes, system settings
- View settings without password protection
- View journal
- Manual flushing valve operation

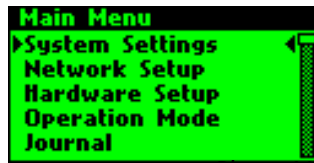
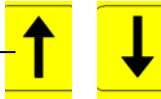

Photo 11

„Scroll back / forward“:
 Select submenus



Arrows indicate selected

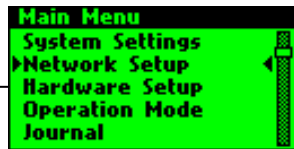

Photo 12

Scrollbar – shows the position within the menu

1 x „OK“ go to submenu

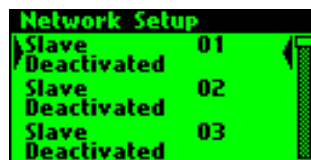

Photo 13

Further operations within the menu:

„Scroll back / forward“:
 Select within menu



„OK“
 Confirm entry / change



„Esc“
 Go back



7.3 Setting the Time and Date

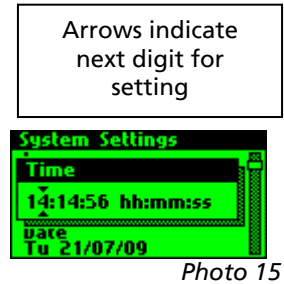
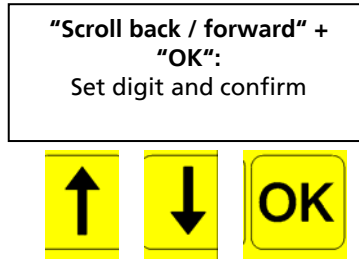
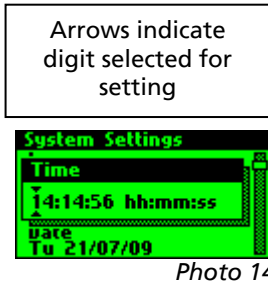

7.4 Setting Flushing Times and Weekly Flushing Programs

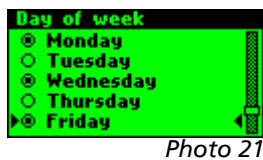
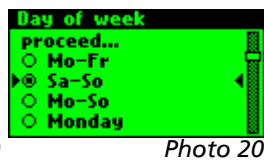
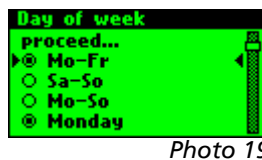
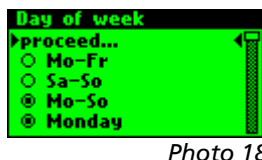
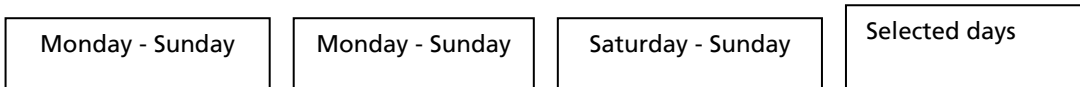
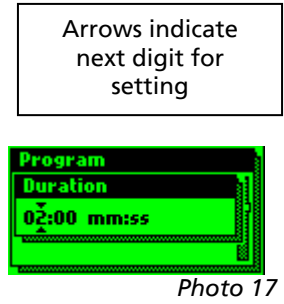
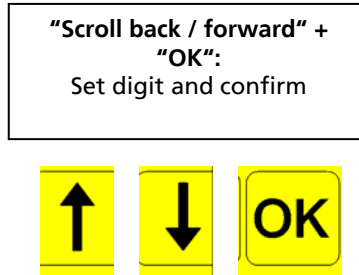
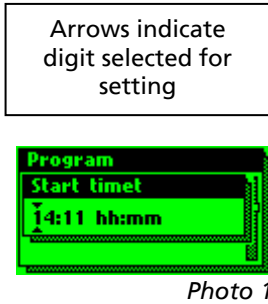

8. Start-Up

Information for flawless start-up:

It is essential to fill in the "System Overview" document as part of the installation process! Perform settings at the control unit in accordance with the description contained in Pos. 8!

The included "System Overview" document needs to be filled in as part of the installation process in accordance with the example (see illustration) if the system settings are to be performed in an easy and flawless manner. The data will subsequently be transferred to the control when the system is started up at the MASTER.

Table 1: Overview for System Start-Up at KHS-Mini System Control Unit -MASTER- Fig. 686 02 005
(Fill in by hand as shown in example as part of the installation process!)

Entry at "Network Setup" -MASTER- Menu Option			Entry at "Hardware Setup" -MASTER- Menu Option								
Object name:			KHS-VAV Maximum Flow Stop Valve with Spring Reset Servo Drive	KHS-VAV Maximum Flow Stop Valve with Servo Drive	KHS Flowmeter Fitting DN20 5-100l/min.	KHS Flowmeter Fitting DN25 10-200l/min.	KHS Flowmeter Fitting DN15 3.5-50l/min.	KHS Flowmeter Fitting DN20 5-85l/min.	KHS Flowmeter Fitting DN25 9-150l/min.	KHS Temperature Sensor PT1000	KHS Free Discharge with Overflow Monitoring
Date:			Figure 686 05	Figure 686 04	Figure 638 00 020	Figure 638 00 025	Figure 638 4G 015	Figure 638 4G 020	Figure 638 4G 025	Figure 628 0G 629 0G	Figure 688 00
Control Unit	No.	Serial No. (type plate on side of control unit)	Ort / Raum	or + or		Example		+		+	
MASTER			Bldg. 2 / Room 2.03	X		X					X
SLAVE	1	001007	Bldg. 2 / Room 2.05	X			X			X	X
MASTER											
SLAVE	1										
SLAVE	2										

Illustration 14: Document excerpt „System Overview“

8.1 Network Setup / Network Settings

1. Go to the main menu with **Esc** (of Main Menu still not indicated)
2. Select network setup submenu
3. Select slave unit 01
4. Confirm password 0000 (factory configuration, can be changed in system settings) – 4 x **OK**
5. Assign serial number to slave unit 01 in accordance with the „System Overview“ document
6. Assign further slave units, return to main menu after completion

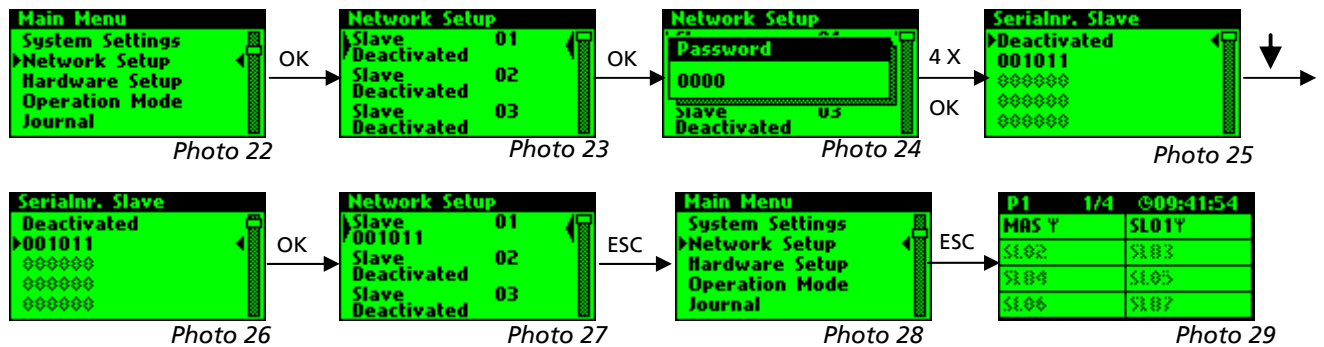

-MASTER- LED



Bild 15

-SLAVE- LED



Bild 16

7. Check!

Antenna symbol appears permanently in the overview, LED lights up green permanently.
 If yes, continue with start-up in compliance with the instructions.
 If not, see Table 3 Error Description / Troubleshooting.

8.2 Hardware Setup

1. Select hardware setup submenu
2. Select appliance
3. Select flushing valve in compliance with „System Overview“ Table 1 and assign to appliance

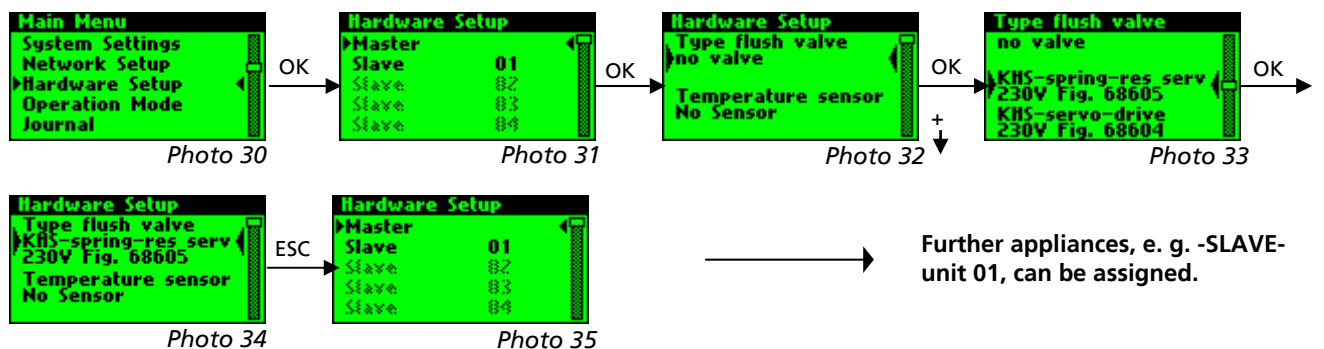

4. Select temperature sensor in compliance with “System Overview“ Table 1 and assign to appliance (only if provided, otherwise continue)

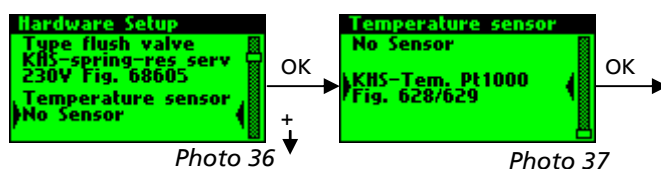

- Select suitable volume flow sensor (**Caution: pay attention to nominal width!**) in compliance with "System Overview" Table 1 and assign to appliance (only if provided, otherwise continue)

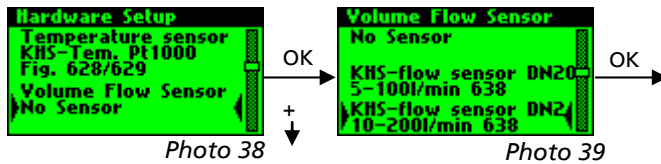

- Alarm relay setup (merely optional, otherwise continue)

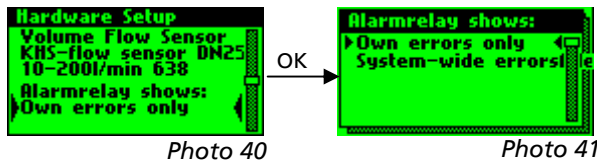

- Perform all further hardware settings for the existing appliances (-SLAVE- Ø 1 bis xx) as described in steps 1 - 6.

8.3 Valve Function Test in Manual Operation

Performing the function test described below is recommended in order to ensure the functionality of all the flushing valves.

- Select manual operation valve submenu
- Select appliance
- Change from automatic to „Manual open“
- Limit opening time (e. g. 30 min.)
- Visually check the flushing valve!

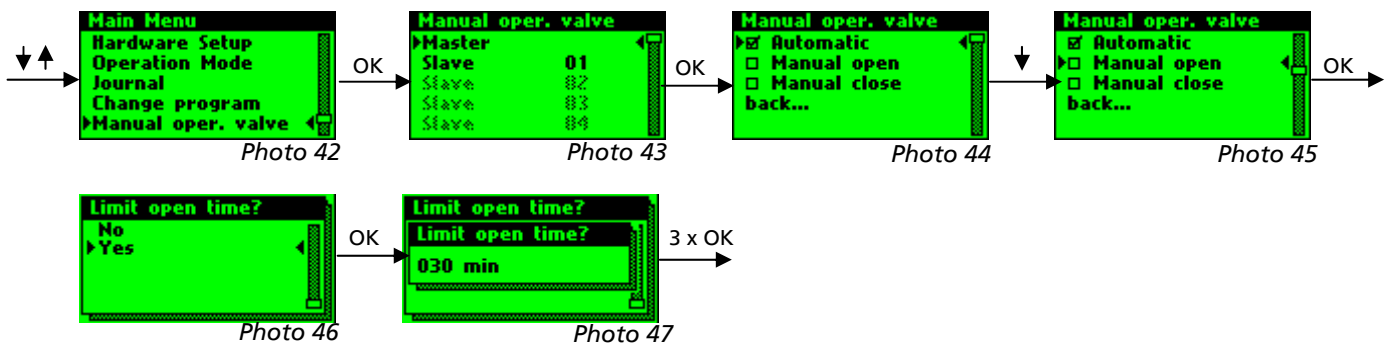

- Select "Manual close" - Switch back to Automatic

- Perform all further function tests for the existing appliances as described in steps 1 to 7.

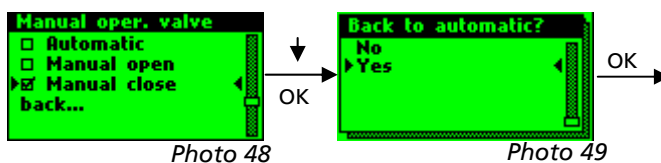

8.4 Operation Modes

- Select operation mode submenu

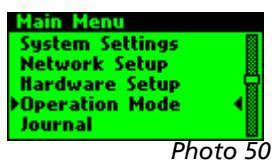

- 1-16 Timers can be set per appliance using time, volume and temperature control.

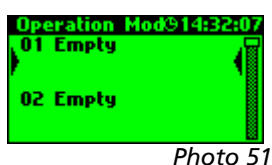

3. Set time control. Example MASTER timer 01

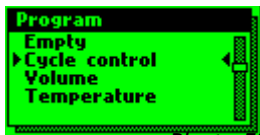

Photo 52



Photo 53

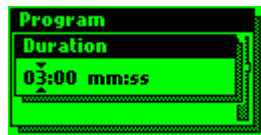

Photo 54



Photo 55



Photo 56

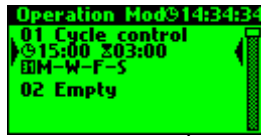

Photo 57

4. Set flushing volume (e. g. 20 litres). Example MASTER timer 02



Photo 58

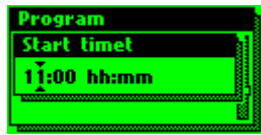

Photo 59



Photo 60



Photo 61



Photo 62

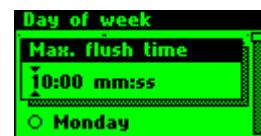

Photo 63

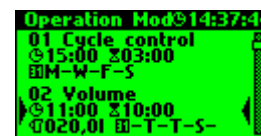

Photo 64

5. Set temperature control. Example MASTER timer 03 / Release Period Optional / Flushing at 25 °C / Flush stop at 22 °C

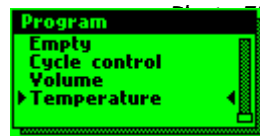

Photo 65

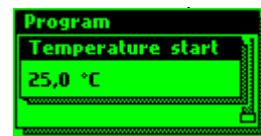

Photo 66

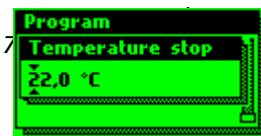

Photo 67

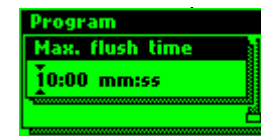

Photo 68

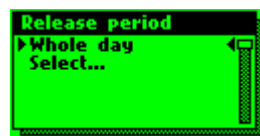

Photo 69

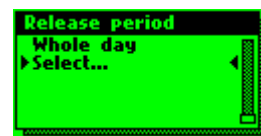

Photo 70

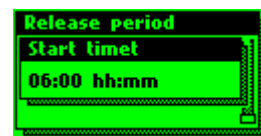

Photo 71

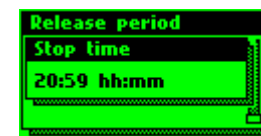

Photo 72



Photo 73

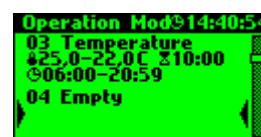

Photo 74

6. Perform all further operation mode settings for the existing appliances as described in steps 1 to 7.

7. If only a temperature control is set up for an appliance, the control system automatically specifies a changeable time control (routine flushing)! This serves to provide the regular weekly flushing process if the flushing start temperature entered is not reached. The flushing duration for the routine flushing process needs to be adjusted in accordance with the pipe capacity!

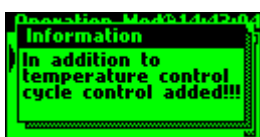

Photo 75

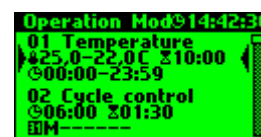

Photo 76

8. Check!: visually check the overview for error messages.

If no, the system is ready for operation

If yes, see Error Description / Troubleshooting Table 3

The start-up process is completed once the operating modes have been entered!
All further settings can be applied optionally.

8.5 System Settings

1. Select system settings submenu

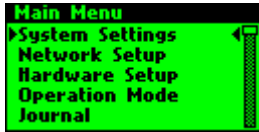

Photo 77

2. Select language German, English or Dutch.



Photo 78



Photo 79

3. Set the time

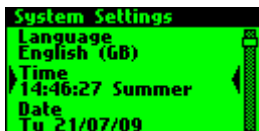

Photo 80

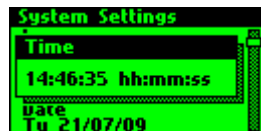

Photo 81

4. Set the date

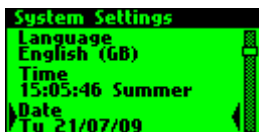

Photo 82

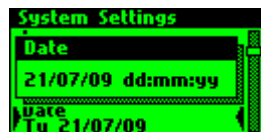

Photo 83

5. Select automatic winter / summer time adjustment

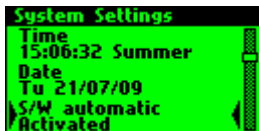

Photo 84



Photo 85

6. Alarm buzzer ON/OFF

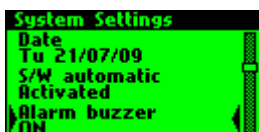

Photo 86

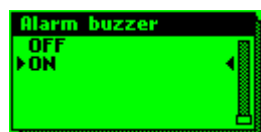

Photo 87

7. Button acknowledgement ON/OFF

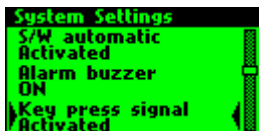

Photo 88



Photo 89

8. Adjust optional display contrast

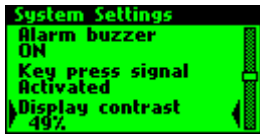

Photo 90



Photo 91

9. Adjust display backlight

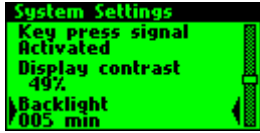

Photo 92



Photo 93

10. Create new password / Factory Default!: 0000



Photo 94

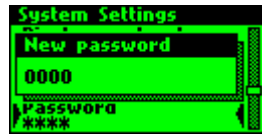

Photo 95

Keep password in a safe place!
No parameters can be changed
without the password!

11. Reset to factory default parameters

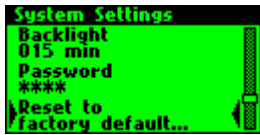

Photo 96

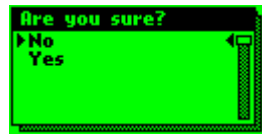

Photo 97

12. Delete all operation modes

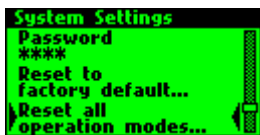

Photo 98

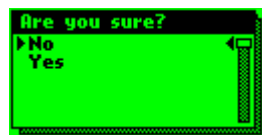

Photo 99

13. Clear complete journal

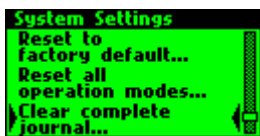

Photo 100

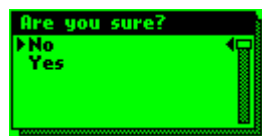

Photo 101

14. Return to main menu

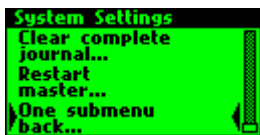

Photo 102

8.6 Program Changeover in -MASTER- Menu or via External 230V Switch Input at -MASTER-

The program change function allows the entry of two different flushing programs (e. g. school holiday operation: many flushing processes / school operation: fewer flushing processes), as well as providing an opportunity for locking the system for maintenance operation (all operation modes will be suspended and are blocked).

The changeover can be performed directly at the MASTER unit (change program submenu), or via an external 230V switch input, or with the PC software (optional accessory).

1. Select change program submenu
2. If change program is "deactivated", changeover between „Program 1“ and "System locked" is possible

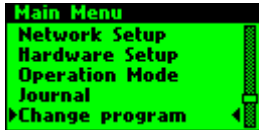

Photo 103



Photo 104

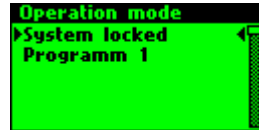

Photo 105

3. If change program is „activated“, changeover between „Program 1“, „Program 2“ and „System locked“ is possible

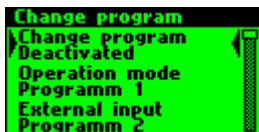

Photo 106

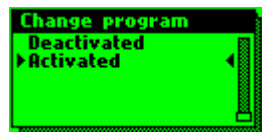

Photo 107

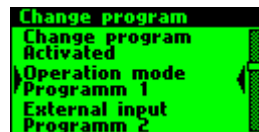

Photo 108

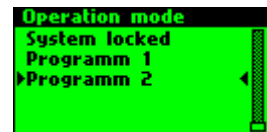

Photo 109

4. In the operation modes you are now being asked for the program this applies to
5. In the detailed overview, the active program is displayed on the top left (e. g. P1 => P2, program 1 is overdriven by program 2, program 2 is active)



Photo 110

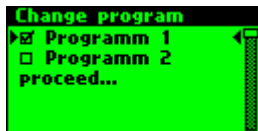

Photo 111

6. Program changes using the external 230V switch input also allow changeovers between „program 1“, „program 2“ and „system locked“. To this end the corresponding program needs to be selected at the „external input“ menu entry. If the input is now permanently provided with 230V, the program will be overdriven in compliance with the settings (e. g. changeover from "Program 1" to "System locked").

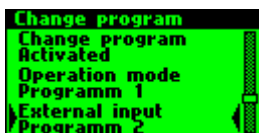

Photo 112



Photo 113

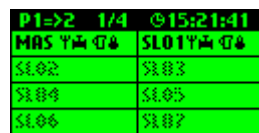

Photo 114

8.7 Journal

All the possibly performed flushing operation modes, error messages and parameter changes are traceably recorded and listed in the journal in accordance with the description in Table 2. The individual operations are provided with the date, time and a description for comprehensibility and traceability.

The journal stores the last 4000 entries on a FIFO basis: starting from 4001 entries the first data entries will be deleted.

1. View journal



Photo 115

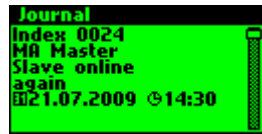

Photo 116

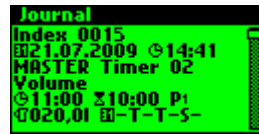

Photo 117

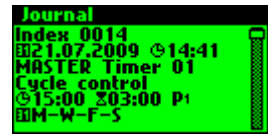

Photo 118

Journal entries with time and date		
Flushing Log	Error	Parameter Change
time control	backpressure free discharge	factory parameters loaded
volume control	temp. control switched off via running time	all operation modes deleted
temperature control	volume control switched off via running time	journal deleted
	temperature measuring range exceeded	control locked
	temperature measuring range fallen short of	control set to program 1
	volume measurement too small	control set to program 2
	volume measurement too large	ext. switch locks control
	real time clock data inconsistent	ext. switch changes to program 1
	SLAVE availability restored	ext. switch changes to program 2
	CAN bus cable error	parameter(s) changed from PC
	no response from SLAVE	first start-up performed
	Mains power switched off	time changed
	Mains power switched on	date changed
		password changed
		language changed
		S/W changeover changed
		alarm settings changed
		button acknowledgement changed
		display contrast changed
		backlighting changed
		SLAVE serial number changed
		valve type changed
		temperature sensor changed
		flow sensor changed
		alarm relay function changed
		switching cycles deleted
		program 2 active changed
		ext. switch function changed
		timer changed
		journal read out from PC

Table 2: all journal entries

The journal can be read out, filtered and stored locally at the MASTER unit via a PC using the **KHS USB adapter cable and the parameterisation and read-out software Figure 686 02 016** included in the accessories. The port for the USB cable is located underneath the black screw cap at the underside of the MASTER unit.

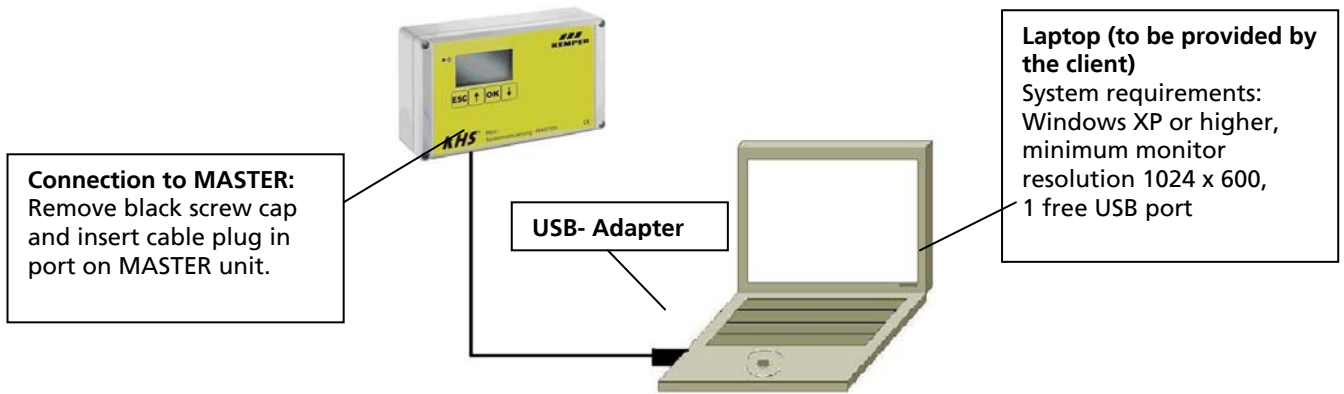

Illustration 15: KHS USB adapter cable with parameterising and read-out software Figure 686 02 016 (optional accessory)

9. Description of malfunctions and malfunction repair

All malfunctions that can occur in the system (see Table 3 below) are reported acoustically with a buzzer on the MASTER- and in that the alarm-relay releases (pulled up (attracted) with voltage during normal operation). During this it does not matter what kind of impact the malfunction could have on the system.

E.g. Malfunction: Backwater in drain / Impact: System is blocked
or Malfunction: No flow detected while valve is open / Impact: Warning message

The control goes into alarm latching and has to be acknowledged after the malfunction has been repaired.

<p><u>Switch off / acknowledge buzzer</u></p> <p>1 x OK buzzer off</p> <p>The control remains in alarm latching</p>	
<p><u>Malfunction display</u> The malfunctions in the MASTER / SLAVE- controls are indicated in the overview flashing with a lightning symbol</p> <p><u>Change to detail display</u></p> <p>2 x OK selected control</p>	
<p><u>Acknowledge malfunction</u> After the malfunction has been repaired, the malfunction can be acknowledged in the detail display</p> <p>1 x OK acknowledge malfunction</p>	

Error Description / Troubleshooting				
Status LED	Error	Possible Cause	Action	Effect
General Errors				
flashes red	backpressure at free discharge	float switch at free discharge has triggered, discharge channel can not accommodate flushing volume	check discharge channel, clean if required, check channel accommodation capacity	Alarm! Control unit is locked
flashes red	backpressure at free discharge	float switch at free discharge has broken cable	replace cable / switch	Alarm! Control unit is locked
flashes red	temp. control switched off via running time	Medium has not reached switch-off temperature in preset time period	Check installation setup	Alarm! Control unit is locked
flashes red	temp. control switched off via running time	Sensor has no / insufficient contact with medium	Check installation setup	Alarm! Control unit is locked
flashes red	volume control switched off via running time	sensor or sensor cable defective	Check installation setup	Alarm! Control unit is locked
flashes red	volume control switched off via running time	set volume has not been reached	Check installation setup	Alarm! Control unit is locked
flashes red	temperature measuring range exceeded	sensor defective / no sensor provided	replace sensor / check entry at MASTER	Alarm! Control unit is locked
flashes red	temperature measuring range fallen short of	sensor defective / no sensor provided	replace sensor / check entry at MASTER	Alarm! Control unit is locked
flashes red	volume measurement too small	sensor defective / no sensor provided	replace sensor / check entry at MASTER	Alarm! Control unit is locked
flashes red	volume measurement too small	short circuit earth & sensor signal	eliminate error	Alarm! Control unit is locked
flashes red	volume measurement too large	sensor defective / no sensor provided	replace sensor / check entry at MASTER	Alarm! Control unit is locked
flashes red	volume measurement too large	short circuit +5V & sensor signal	eliminate error	Alarm! Control unit is locked
flashes red	real time clock data inconsistent	data in clock inconsistent	check time & date, readjustment resets the error, check battery and replace, if required	no time-based service will run as desired if the time / date is wrong
Flashes red	"Flow with closed valve detected"	Flow is detected by the vortex flow sensor with the valve closed	Check the functioning of the flush valve	Warning message!
Flashes red	"No flow detected although valve is open"	No flow is detected during a flushing process.	Check the flush line water supply. Check the functioning of the flush valve	Warning message!
Bus Errors				
flashes orange	no response from SLAVE unit	broken cable, incorrect installation, noise fields	check CAN bus cable and installation	check CAN bus cable and installation
flashes orange	no response from SLAVE unit	SLAVE unit without power	re-establish power supply for SLAVE unit	affected SLAVE unit fails to perform any flushes
flashes orange	no response from SLAVE unit	SLAVE unit with corresponding serial number is no longer part of the system (e. g. following replacement)	assign appropriate serial number to affected SLAVE unit and/or delete the appliance from the system	affected SLAVE unit fails to perform any flushes
flashes orange	CAN bus cable error	broken cable, incorrect installation, noise fields	check CAN bus cable and installation	check CAN bus cable and installation

Table 3: Error description/troubleshooting

10. Dimensions, Installation Dimensions

-MASTER-

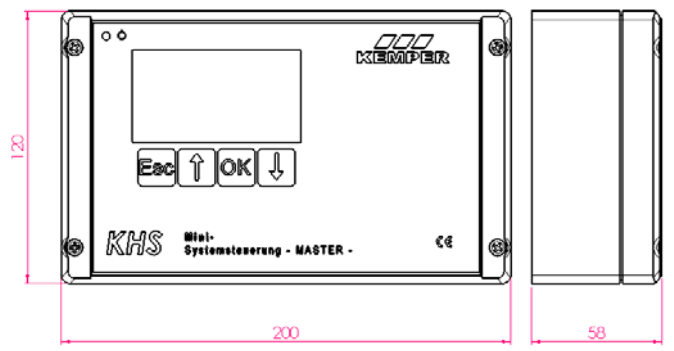

Hole distances MASTER

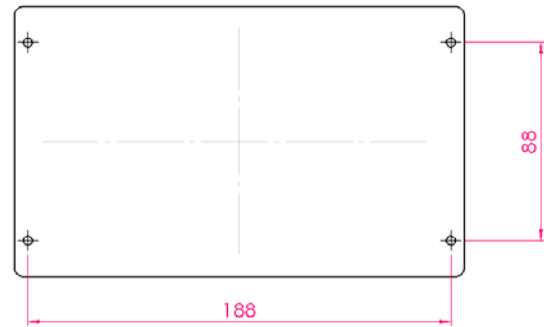

-SLAVE-

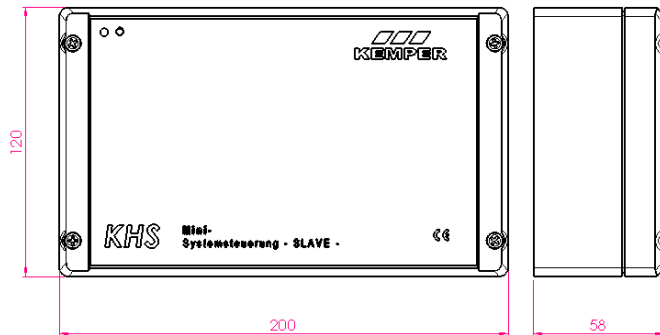

Hole distances SLAVE

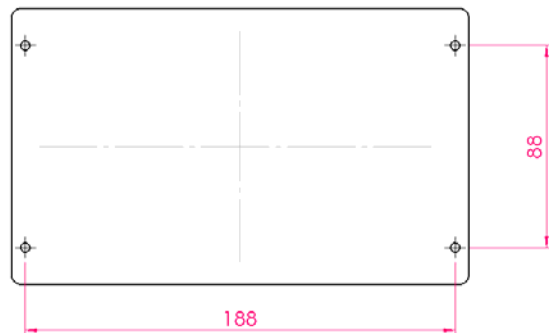

Illustration 16: Dimensions and hole distances for installation bores at MASTER/SLAVE

11. Accessories

Optionally available accessories	
USB adapter cable, parameterising and read-out software – MASTER-	686 02 016
KHS maximum flow stop valve with servo drive 230 V	686 04
KHS maximum flow stop valve plus with spring-reset servo drive	686 05
KHS free discharge with overflow monitoring	688 00
KHS temperature sensor Pt 1000	628 0G / 629 0G
KHS flowmeter	638 00

12. Wiring for KEMPER KHS components with electrical connection

Designation	for Fig. no.	Cable cross-section	max. cable length
	KEMPER	mm ²	m
KHS-VAV plus Maximum flow isolating ball valve with spring-reset servo drive (24V)	686 01 015...032 696 01 015	5 x 0,75 ² 5 x 1,0 ²	220 300
KHS-VAV Maximum flow isolating ball valve with servo drive (24V)	686 00 015...032 696 00 015	6 x 0,5 ² 6 x 0,75 ² 6 x 1,0 ² 6 x 1,5 ² 6 x 2,5 ² 6 x 4,0 ²	29 43 58 86 144 230
KHS-VAV plus Maximum flow isolating ball valve with spring-reset servo drive (230 V)	686 05 015...032 696 05 015	3 x 1,5 ²	9500
KHS-VAV Maximum flow isolating ball valve with servo drive (230 V)	686 04 015...032 696 04 015	4 x 1,5 ²	9500
KHS drain with overflow monitor	688 00 020...032	2 x 0,25 ²	150
Vortex flow sensor (for GLT connection)	638 4G 015...025 138 4G 015...050	7 x 0,34 ² *	300
KHS Timer Set, KHS-VAV, with and without spring-reset servo drive (230 V) in connection with the KHS timer	686 06 / 07 696 06 / 07	von Spannungsquelle zum Timer: 2 x 1,5 ² von Timer zu Stellantrieb: 3 x 1,5 ²	10.000
System control logic (according to customer request)	686 02 003	von Spannungsquelle zur KHS-Logic: 3 x 1,5 ²	10.000
KHS temperature sensor valve Pt 1000	628 0G 015...050 629 0G 015...050	4 x 2 x 0,6	10.000
KHS-hygienic flushing unit with control valves and cover for cold water	686 03 007	von Spannungsquelle zur Hygienespülung 3 x 1,5 ² von Hygienespülung zur Logic 5 x 0,5 ²	10.000 100
KHS-hygienic flushing unit with control valves and cover for cold and warm water	686 03 008	von Spannungsquelle zur Hygienespülung 3 x 1,5 ² von Hygienespülung zur Logic 5 x 0,5 ²	10.000 100
CAN bus cable** The application is standardized internationally in compliance with ISO 11898. Greater lengths require larger duct diameters.	686 02 005 686 02 006	1 x 2 x 0.25 ² ... 0.34 ² 1 x 2 x 0.34 ² ... 0.5 ² 1 x 2 x 0.50 ² ... 0.6 ² 1 x 2 x 0.75 ² ... 0.8 ²	0 m ... 40 m 40 m ... 300 m 300 m ... 600 m 500 m ... 1000 m

* shielded cable feed

** provided by the building contractor

Dated: 31.03.10

Table 4: Wiring Instructions for KEMPER KHS Components with Power Connection