

**Figure 640 05 KHS-Venturi Multi-Circ Distributor Unit,  
Flow and return with MT, Drain DN 20 / 15**

Technical properties
Fluid-contacting parts made completely of gunmetal
For induced flow and continual water exchange in sanitary block
With Venturi nozzle engineering
Minimum pressure loss
Maximum flow isolating ball valve DIN-/DVGW-approved according to DIN EN 13828, W 570
VAV with removable head part 'Top Entry'
Soundproofing tested in accordance with DIN EN ISO 3822
Pressure stage PN 16
Stagnant-zone-free
Insulating shell building material class B1 compliant with DIN 4102



**640 05 KHS-Venturi Multi-Circ Distributor Unit for surface mounting with MT / coupling nut**

Product description / Tender text
<b>KEMPER KHS-Venturi Multi-Circ Distributor Unit</b> , for induced flow-through in sanitary block areas for CDW ring circuit installation cold-water water tapping valves and furnishings, especially suitable for the KEMPER KHS Hygiene System comprising:
<b>Flow distributor</b> based on the Venturi principle, with sanitary block feed line and sanitary block return line with union nut for direct connection to the maximum flow isolating ball, made entirely out of gunmetal, resistant against aggressive water, with soundproofing certificate,
<b>Maximum flow isolating ball valves</b> , zero loss version, compliant with DIN EN 13828 corresponds to the drinking water hygiene requirements according to DVGW W 570, made entirely from gunmetal, resistant against aggressive water, brass-free in areas that touch fluids, with maintenance-free spindle sealing, 'Top Entry' head part can be removed from top, made with EPDM gasket body with rotating-supported gunmetal closing body, stagnant-zone-free, with ergonomically designed 90° rotating handle, with DIN/ DVGW and soundproofing certificate, rated pressure PN 16 and
<b>Insulating shells</b> for maximum flow isolating ball and distributor unit, made of closed cell foamed polyethylene with additional, permanent outer shell, building material class B1 compliant with DIN 4102, Thermal conductivity according to ISO 2581 0.035 W/mK, can be sealed diffusion-resistant with commercially available glues,
<b>Flow distributor</b> inlet and outlet side with outer (male) thread (MT) from DN 20 (1") to DN 32 (1 1/2"), <b>sanitary block feed line</b> with union nut DN 20 (1") <b>and return line</b> with outer (male) thread (MT) DN 15 (3/4"), per each <b>surface mount maximum flow isolating ball valve VAV</b> with DN 20 (1") and DN 15 (3/4") male threads

- For more information please see reverse

Dimensions				
Nominal width	DN	20	25	32
Overall height (H1)	mm	97	107	112
Overall height (H2)	mm	133.5	143.5	148.5
Overall height (H3)	mm	95	104.5	109.5
Overall height (H4)	mm	128.5	138.5	143.5
Length (L1)	mm	185	185	195
Length (L2)	mm	100	100	100
Length (L3)	mm	90	90	90
Connection dimension (A1)		G 1	G 1 1/4	G 1 1/2
Connection dimension (A2)		G 1	G 1	G 1
Connection dimension (A3)		G 3/4	G 3/4	G 3/4

Materials	
Flow distributor	Gunmetal
Housing, interior head part	Gunmetal
Seal element	EPDM
Handle	Plastic
Coupling nut	Brass
Insulating shell	Polyethylene

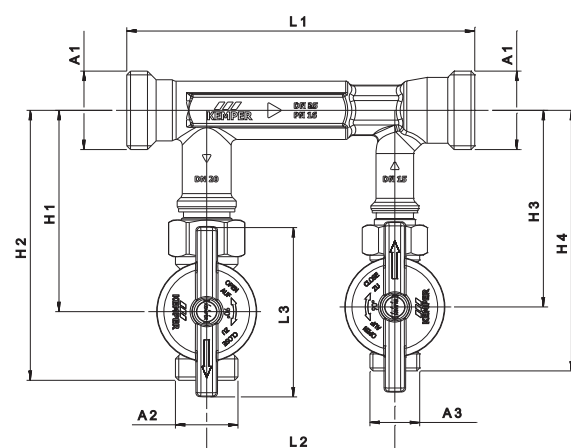

**Figure 640 05 KHS-Venturi Multi-Circ Distributor Unit,  
Flow and return with MT, Drain DN 20 / 15**

<b>Technical information</b>	
<b>Area of application</b>	
<ul style="list-style-type: none"> <li>- The KHS Venturi Multi-Circ Venturi Distributor Unit provides a facility for controlled induced flow-through in drinking water systems by using tailor-made and innovative pipeline network structuring.</li> <li>- Together with the automatic KHS flushing equipment, a continuous drinking water exchange is produced to implement drinking water system operation in accordance with the requirements.</li> <li>- Every time water is withdrawn, which takes place in the flow path behind the KHS-Multi-Circ Venturi Distributor Unit, the water is also moved in the upstream ring lines, producing a continuous exchange.</li> <li>- That means permanent stagnation prevention.</li> <li>- Make sure the CDW line is laid out as a ring line and that all CDW consumers are looped (avoid T-installations).</li> <li>- It is recommended to calculate the hydraulic conditions in the DW system, e.g. with the Dendrit software.</li> <li>- Install the KHS-Multi-Circ Distributor Unit only together with KHS-VAV as KEMPER can only guarantee functional operation in bypass mode only with these valves (0 pressure-loss).</li> </ul>	

<b>Figure</b>	<b>Flow distributor unit</b>	<b>Concealed VAV</b>	
		<b>Feed line</b>	<b>Return line</b>
	<b>Throughlet</b>		
640 05 020	AG 1"	AG 1"	AG 3/4"
640 05 025	AG 1 1/4"	AG 1"	AG 3/4"
640 05 032	AG 1 1/2"	AG 1"	AG 3/4"