

Figure 660 00 KHS Concealed Dynamic Flow Distributor Group for Geberit inliner system, Flow and return with FT, returns DN 20/20

Technical properties	
Fluid-contacting parts made completely of gunmetal	
Temperature maintenance in the WDW system through integrated cartridge and inliner piping system	
Maximum flow isolating ball valve DIN-/DVGW approved according to DIN EN 13828, W 570	
Maximum flow isolating ball valve with removable 'Top Entry' inner head part	
Soundproofing tested in accordance with DIN EN ISO 3822, Class 1	
Pressure stage PN 16	
Insulating shell building material class B1 compliant with DIN 4102	
Stagnant-zone-free	



660 00 Dyn. Flow Distributor Group for Geberit inliner system, for concealed installation

Product description / Tender text
<p>KEMPER KHS-Dynamic Flow Distributor Unit Group for Geberit inliner system, for concealed installation in the sanitary block area, for inliner circulation of WDW in the sanitary block in ring circuit installations and temperature maintenance, especially suitable for the KHS KEMPER Hygiene System, comprising:</p> <p>Dynamic Flow Distributor based on the Venturi principle, including cartridge for the dynamic Venturi nozzle, plus pipeline conduction for dedicated mounting of the inliner, with sanitary block feed line and sanitary block return line, made completely from gunmetal, resistant against aggressive water, with Class 1 soundproofing certificate,</p> <p>Concealed Maximum flow isolating ball valves, zero loss version, compliant with DIN EN 13828, corresponds to the drinking water hygiene requirements according to DVGW W 570, made entirely from gunmetal in the fluid contact area, resistant against aggressive water, with maintenance-free spindle sealing, 'Top Entry' inner head part can be removed from above, made of EPDM gasket body with rotating-supported gunmetal closing body, stagnant-zone-free, with continuously adjustable, plastic shaft, installation depth up to 110 mm, as wall installation unit- Assembly kit 1, with DIN/ DVGW and soundproofing certificate, rated pressure PN 16 and</p> <p>Insulating shells for maximum flow isolating ball valve and flow distributor, made of closed cell foamed polyethylene with additional, permanent outer shell, building material class B1 compliant with DIN 4102, thermal conductivity according to ISO 2581 0.035 W/mK, incl. stopper clips, can be sealed diffusion-resistant with commercially available glues,</p> <p>Flow distributor inlet and outlet side with female thread from DN 25 (1") to DN 32 (1 1/4"), Sanitary block feed line and return line with female thread DN 20 (3/4"), Concealed maximum flow isolating ball with female thread DN 20 (3/4")</p>

Optionally accessories	
Final assembly set with handle	590 00 025
Final assembly set change stopper	591 00 025

- Please see reverse for additional technical information
 - Take technical information on Geberit inliner into consideration

Dimensions			
Nominal width	DN	25	32
Overall height (H1)	mm	68,5	73,5
Length (L1)	mm	212	227
Length (L2)	mm	100	100
Length (L3)	mm	90	90
Connection dimension (A1)		Rp 1	Rp 1 1/4
Connection dimension (A2)		Rp 3/4	Rp 3/4

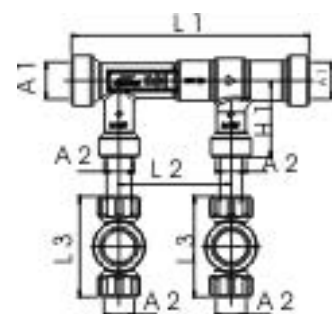

Materials	
Flow distributor	Gunmetal
Flow body	POM
Housing, head part	Gunmetal
Seal element	EPDM
Shaft, push-on spindle, cap	Plastic
Insulating shell	Polyethylene

**Figure 660 00 KHS Concealed Dynamic Flow Distributor Group
for Geberit inliner system,
Flow and return with FT, returns DN 20/20**



Technical information

Scope of application

- The KHS Dynamic Multi-Circ Distributor Unit provides controlled forced flow in cold (CDW) and warm (WDW) drinking water systems. To maintain the temperature (> 55 °C) in CDW systems, engineering and calculation with calculation software is necessary (the KEMPER-Dendrit software is recommended).
- That means it is possible to implement permanent stagnation prevention in CDW and WDW systems. In CDW systems, temperature maintenance can be implemented in accordance with DVGW W551.
- Make sure the drinking water plumbing in the sanitary block is executed as a ring line and that all drinking water consumers are looped (avoid T-installations).
- It is recommended to calculate the hydraulic conditions of the DW system, e.g. with the Dendrit software, to achieve planning reliability before execution.
- Install the KHS Dynamic Distributor Unit only together with KHS-VAV shut off technology as only these valves (0 pressure-loss) can guarantee reliable operation in ring-line systems.
- **Attention:** When selecting the dynamic distributor unit, please note the differentiation between dynamic distributor units (marked on housing as „D I“, Figure 650) and dynamic distributor units with inliner systems (marked on housing as „D II“, Figure 660)
- To install the KHS Dynamic Flow Distributor Group for the Geberit inliner system, follow the operating instructions from Geberit for inliner systems along with the KEMPER operating instructions. Fast, unproblematic component installation is only feasible when the operating instructions are understood.

Figure 660 06 KHS Surface Mounted Dynamic Flow Distributor Group for Geberit inliner system, Flow and return with FT, returns DN 20/20

Technical properties

Fluid-contacting parts made completely of gunmetal
 Temperature maintenance in the WDW system through integrated cartridge and inliner piping system
 Maximum flow isolating ball valve DIN-/DVGW approved according to DIN EN 13828, W 570
 Maximum flow isolating ball valve with removable 'Top Entry' inner head part
 Soundproofing tested in accordance with DIN EN ISO 3822, Class 1
 Pressure stage PN 16
 Insulating shell building material class B1 compliant with DIN 4102
 Stagnant-zone-free



660 06 Dynamic Flow Distributor Group for Geberit inliner system, for surface mounting

Product description / Tender text

KEMPER KHS-Dynamic Flow Distributor Unit Group for Geberit inliner system, for surface mounting in the corridor area, for inliner circulation of WDW in the sanitary block in ring circuit installations and temperature maintenance, especially suitable for the KHS KEMPER Hygiene System, comprising:

Dynamic Flow Distributor based on the Venturi principle, including cartridge for the dynamic Venturi nozzle, plus pipeline conduction for dedicated mounting of the inliner, with sanitary block feed line and sanitary block return line, made completely from gunmetal, resistant against aggressive water, with Class 1 soundproofing certificate,

Surface mounted Maximum flow isolating ball valves, zero loss version, compliant with DIN EN 13828, corresponds to the drinking water hygiene requirements according to DVGW W 570, made entirely from gunmetal in the fluid contact area, resistant against aggressive water, with maintenance-free spindle sealing, 'Top Entry' inner head part can be removed from above, made of EPDM gasket body with rotating-supported gunmetal closing body, stagnant-zone-free, with ergonomically designed 90° operating handle, with DIN/DVGW and soundproofing certificate, rated pressure PN 16 and

Insulating shells for maximum flow isolating ball valve and flow distributor, made of closed cell foamed polyethylene with additional, permanent outer shell, building material class B1 compliant with DIN 4102, thermal conductivity according to ISO 2581 0.035 W/mK, incl. stopper clips, can be sealed diffusion-resistant with commercially available glues,

Flow distributor inlet and outlet side with female thread from DN 25 (1") to DN 32 (1 1/4"),

Sanitary block feed line and return line with female thread DN 20 (3/4"),

Surface mounted maximum flow isolating ball valve with female thread DN 20 (3/4")

Optionally accessories

Connection screws 476

- Please see reverse for additional technical information
 - Take technical information on Geberit inliner into consideration

Dimensions

Nominal width	DN	25	32
Overall height (H1)	mm	68,5	73,5
Length (L1)	mm	212	227
Length (L2)	mm	100	100
Length (L3)	mm	90	90
Connection dimension (A1)		Rp 1	Rp 1 1/4
Connection dimension (A2)		Rp 3/4	Rp 3/4

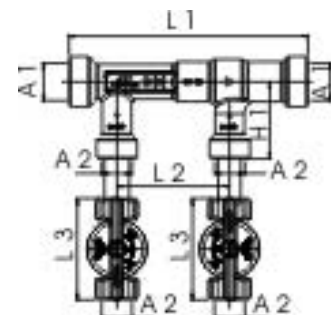

Materials

Flow distributor	Gunmetal
Flow body	POM
Housing, head part	Gunmetal
Seal element	EPDM
Handle	Plastic
Insulating shell	Polyethylene

**Figure 660 06 KHS Surface Mounted Dynamic Flow Distributor
Group for Geberit inliner system,
Flow and return with FT, returns DN 20/20**

Technical information

Scope of application

- The KHS Dynamic Multi-Circ Distributor Unit provides controlled forced flow in cold (CDW) and warm (WDW) drinking water systems. To maintain the temperature (> 55 °C) in CDW systems, engineering and calculation with calculation software is necessary (the KEMPER-Dendrit software is recommended).
- That means it is possible to implement permanent stagnation prevention in CDW and WDW systems. In CDW systems, temperature maintenance can be implemented in accordance with DVGW W551.
- Make sure the drinking water plumbing in the sanitary block is executed as a ring line and that all drinking water consumers are looped (avoid T-installations).
- It is recommended to calculate the hydraulic conditions of the DW system, e.g. with the Dendrit software, to achieve planning reliability before execution.
- Install the KHS Dynamic Distributor Unit only together with KHS-VAV shut off technology as only these valves (0 pressure-loss) can guarantee reliable operation in ring-line systems.
- **Attention:** When selecting the dynamic distributor unit, please note the differentiation between dynamic distributor units (marked on housing as „D I“, Figure 650) and dynamic distributor units with inliner systems (marked on housing as „D II“, Figure 660)
- To install the KHS Dynamic Flow Distributor Group for the Geberit inliner system, follow the operating instructions from Geberit for inliner systems along with the KEMPER operating instructions. Fast, unproblematic component installation is only feasible when the operating instructions are understood.